

P. Arokiasamy*

Determinants of Demographic Changes in India: An Analysis Using New Transformation of Variables

Introduction

RECENT research has underscored that the interrelationships among demographic and socio-economic variables are considerably more complex than those visualised in the earlier analyses of demographic transition (Mason *et al.*, 1986; Blanchet, 1991). A multiplicity of changing factors govern the complex relationships between population and socio-economic parameters. Because of the increasing complexity of the relationships, the pattern of linkages between socio-economic development and demographic processes continues to be important area of research and analyses for formulation of more appropriate policy perspectives. Changing demographic processes could be simultaneous or time-lag consequences of socio-economic development processes and the latter in part could be the causal consequences of the former. To briefly outline the details of the processes, population growth is a function of fertility and mortality change in the absence migration, but fertility change is the outcome of mortality decline, improvements in educational attainment, rapid urbanization and economic growth, besides apparent family planning efforts. Mortality decline on the other hand, is dependent on advancement in medical care, improvements in health, nutrition and sanitation situation, educational levels, urbanization and economic growth. The changes in one variable and the consequent changes in another are closely interwoven and interconnected with other variables as well. Population growth is, therefore, determined by the processes of simultaneous

* International Institute for Population Sciences, Deonar, Bombay- 400 088.

changes or as the outcome of lagged effects of changes over the multiplicity of variables.

According to Blanchet (1991) at the onset of demographic transition, the association between demographic and socio-economic parameters or the lack of it may suffer from simultaneity bias. And during transition period varying patterns of association could be observed including the reemergence of a negative correlation at a later stage of development. With increasing complexity in the process of demographic changes, nonlinear or more dynamic relationships including the time lag component and suitable conceptual models are required to be visualised for a comprehensive examination and better understanding of the factors affecting demographic changes. In this context, most of the previous research studies tried to understand demographic and socio-economic changes with the help of cross-sectional analyses using variables level across the units of study which are inadequate to bring out the complex processes of changes. Box and Tidwell (1962) Box and Cox (1964) have stressed about the need to use more appropriate transformation of variables while applying statistical models. Problems are also faced in using appropriate statistical procedures. In aggregate these constraints brought limitation on the scope of empirical research analysis of demographic changes taking place within countries to understand the principal factors that determine the observed demographic changes.

Substantial amount of demographic changes have taken place in India over the past three decades from 1961-71 to 1981-91. Scientific understanding of the factors affecting demographic processes of population growth, fertility, mortality and family planning changes were limited as result of the above mentioned constraints, and also the availability of more relevant data. In the background of the perspective, the present analysis attempts to gain a better insight of the factors affecting the demographic changes in India and the constraints encountered in earlier analyses have been tackled considerably as follows. First, a cross-sectional and time-trend data set is used; second, newer variables such as sector-wise real income growth and more appropriate transformation of variables have been used; and third, improvised statistical procedures and explanatory models have been tried taking into account the dimension of time-lag effects as well.

Data and Methods

The cross-sectional and time-trend data set used in the present analysis is a ten yearly interval data of socio-economic and demographic changes for India and major states of India from 1961 to 1991 gathered from Census of India, Sample Registration System, Family Welfare Year Book and publications of Centre for Monitoring Indian

Economy. This is a dynamic data set, which is multivariate, time-trend and cross-section of changes. The cross-section is across the states and India and the time-trend is decade wise change from 1961 -91 over the cross-section. Multiple linear regression analysis and Wheeler's (1984) log-linear specification econometric model, have been used to examine the factors affecting demographic changes over the three decades period, taking into account appropriate dimensions of simultaneous or time-lag changes. The econometric model specified by Wheeler is a simultaneous and time change model over a log-linear function. The Wheeler model has been built on cross-section of changes overtime, rather than levels across countries and used logarithm of percentage changes. This is a linear regression with logarithm of variables of changes. The Wheeler output equation is basically derived from the Cobb-Douglas function. The log-linear function specified by Wheeler is

$$\langle dq \rangle = a_0 + \sum_{i=1}^n a_i \langle dj \rangle + u.$$

$$i, j = 1, 2, 3 \dots n.$$

$\langle dq \rangle$ - changes in output (criterion variable).

$\langle dj \rangle$ - changes in input (explanatory variables).

u - random error.

A more appropriate transformation of variables used in the present analysis is, logarithm of relative changes, which is an improvement over the transformation of logarithm of percentage changes used in Wheeler's model. The 'relative change' takes into account both the level and magnitude of change in the variables over the period of time. The relative pace of change is defined here as the ratio in percentage between the actual magnitude of change recorded and the magnitude of change required to be attained during the particular period (decade) in respect of the particular variable chosen. The latter (denominator) is actually the difference between the maximum attainable level and the level at the initial year of the particular decade.

1. To cite an example, regarding the limitations of using levels or percentage changes, if for instance, percent literate is an explanatory variable under consideration say over the period of 1961 -71 to 1981 -91, the state of Kerala will be characterized with the highest literacy level both in 1961 and 1991 as it starts with the highest level, and a state like Bihar will be characterized with low levels over the period. In this type of situation if the variable is treated on the basis of level, the explanatory power of education in respect of Kerala will continue to remain higher over the period 1961 -71, 1971 -81 and 1981 -91 compared to the states with lower levels regardless of even a faster pace of change in these states. On the other hand, if percentage change alone is taken as a variable the pace of change in Bihar will be shown as higher compared to Kerala although the magnitude of change could be far higher in Kerala. In such circumstances, the relative pace of change, will be a more appropriate transformation for examining the changes.

The relative pace of change for each decade was computed as follows:

$$RC = (LP_{i+1} - LP_i) / (MAALP_n - LP_i) * 100 \quad (1)$$

$i = 1$ (1961), 2 (1971), 3 (1981), 4 (1991) n in this analysis.

RC is Relative Change (index of level and change).

LP_i is Level at Period i

LP_{i+1} is Level at Period $i + 1$.

$MAALP_n$ is Maximum Attainable Level (arbitrary) at period n .

For a variable like infant mortality rate, where change takes place in the declining order, the corresponding transformation will be

$$RC = (LP_i - LP_{i+1}) / (LP_i - MIALP_n) * 100 \quad (2)$$

Here $MIALP_n$ would refer to minimum attainable level at period n . The maximum/minimum attainable levels were fixed, based on the experience of the leading states in the respective parameter. Where change takes place in the declining order corresponding transformations were obtained using minimum attainable levels.

For variables, rate of population growth and sectoral income growth, exponential annual growth rates were considered more appropriate. For variable fertility change both simple percentage change in total fertility rate and relative change in total fertility rate have been utilized. For the remaining variables 'relative change' transformation was considered appropriate. The variables chosen for the analysis with respective transformations are as follows:

PG_e - Population Growth—Annual Exponential Growth.

EGO_e - Economic Growth—Annual Exponential Growth in NDP (Net Domestic Product at factor cost and at constant prices) per capita of states/ India—Overall (Inclusive of all sectors).

EGP_e - Economic Growth—Annual Exponential Growth in NDP per capita—Primary Sector.

EGS_e - Economic Growth—Annual Exponential Growth in NDP per capita—Secondary Sector.

EGT_e - Economic Growth—Annual Exponential Growth in NDP per capita—Tertiary Sector.

FC_p - Fertility Change—Percent Change in Total Fertility Rate (TFR).

FC_r - Fertility Change—Relative Change in TFR.

FPC_r - Family Planning Acceptance Change—Relative Change in Couple Protection Rate (CPR).

PMCr - Proportion Married Change—Relative Change in Proportion Married among Females in the age group 15-19.

IMCr - Infant Mortality Change—Relative Change in Infant Mortality Rate (IMR).

PLFCr - Proportion Literate among Females—Relative Change.

PENAFCr - Proportion Employed in Nonagricultural Sector among Employed Females—Relative Change

PUCr - Percent of Urban Population—Relative Change.

A series of regression analyses including Wheeler's non-linear regressions were performed to understand the factors affecting the demographic changes in India.

Results and Discussions

Determinants of Population Growth

Table 1 shows the correlation matrix of the overall data set. It may be observed that significant negative correlations are indicated only for three variables viz. female literacy, infant mortality, and family planning acceptance changes with population growth. The negative correlations indicate that higher level of changes in these factors have been accompanied by slower population growth simultaneously. However, the correlation matrix in Table 2 obtained after log transformation² of the population and socio-economic parameters indicates that six variables are significantly correlated with population growth. These results reveal that faster income growth rates in secondary and tertiary sector, higher level of relative change in female literacy, infant mortality, fertility and family planning acceptance are associated with slower pace of population growth.

Taking the above six significant variables together with urbanisation change as explanatory variables of population growth, multiple linear regression analysis however, did not show any clear cut results (not shown), for the overall data set. The fitting of a log-linear regression model indicated only infant mortality change as a determinant, while *R* square itself was found to be insignificant. This is quite a surprising trend given the fact that most of the important variables showed significant bivariate correlation with population growth. Therefore, more suitable models and

2. It may be noted that the direction of relationship changes from + (positive) to - (negative) or from - (negative) to + (Positive) for some of the variables between simple regression model and log linear regression model. This happens because of the additional transformations effected such as deduction of the values of the variables from a larger constant value in order to secure a sufficient value for taking logarithms.

TABLE 1: CORRELATION MATRIX OF POPULATION AND SOCIOECONOMIC VARIABLES (of changes) ($N = 45$)

Variables\$	<i>PGe</i>	<i>EGOe</i>	<i>EGPe</i>	<i>EGSe</i>	<i>EGTe</i>	<i>FCp</i>	<i>IMCr</i>	<i>FPCr</i>	<i>PLEr</i>	<i>PENAFCr</i>	<i>PUCr</i>
<i>PGe</i>	1.000										
<i>EGOe</i>	0.015	1.000									
<i>EGPe</i>	0.122	0.535*	1.000								
<i>EGSe</i>	-0.192	0.327**	0.662*	1.000							
<i>EGTe</i>	-0.195	0.447**	0.735*	0.816*	1.000						
<i>FCp</i>	0.195	0.079	0.055	0.034	-0.092	1.000					
<i>IMCr</i>	-0.343**	0.076	0.097	0.276**	0.213	-0.377*	1.000				
<i>FPCr</i>	-0.359*	0.317**	0.144	0.206	0.341**	-0.287**	0.304**	1.000			
<i>PLFr</i>	-0.482*	-0.051	0.114	0.308*	0.306**	-0.524*	-0.603*	0.464*	1.000		
<i>PENAFCr</i>	-0.060	0.004	0.094	0.371	0.095	-0.130	0.284**	-0.127	0.063	1.000	
<i>PUCr</i>	-0.110	-0.129	-0.169	0.193	0.251**	-0.250	0.3014**	0.417	0.382	0.039	1.000

* $P < 0.01$, ** $P < 0.05$, *** $P < 0.10$; Unmarked coefficients are not significant.

\$ Abbreviation of variables are given in Appendix.

TABLE 2 : CORRELATION MATRIX OF LOG TRANSFORMED POPULATION AND SOCIOECONOMIC VARIABLES ($N = 45$)

Variables	<i>PGe</i>	<i>EGOe</i>	<i>EGPe</i>	<i>EGSe</i>	<i>EGTe</i>	<i>FCr</i>	<i>IMCr</i>	<i>FPCr</i>	<i>PLFCr</i>	<i>PENACr</i>	<i>PUCr</i>
<i>PGe</i>	1.000										
<i>EGOe</i>	0.021	1.000									
<i>EGPe</i>	0.175	0.527*	1.000								
<i>EGSe</i>	0.251**	0.316**	0.673*	1.000							
<i>EGTe</i>	0.254**	0.439*	0.744*	0.822*	1.000						
<i>FCr</i>	-0.211***	0.076	0.045	0.026	-0.107	1.000					
<i>IMCr</i>	0.480*	-0.004	0.326**	0.487**	0.431*	0.401*	1.000				
<i>FPCr</i>	0.332**	-0.363*	-0.093	-0.229***	-0.393*	0.430*	-0.317**	1.000			
<i>PLFCr</i>	-0.439*	-0.070	-0.002	0.205***	-0.280**	0.576*	-0.528*	0.694*	1.000		
<i>PENACr</i>	0.086	0.027	0.143	0.199	0.153	-0.170	0.374*	0.108	-0.074	1.000	
<i>PUCr</i>	-0.153	0.100	0.142	-0.179	-0.283***	0.367*	-0.261**	0.495*	0.494*	0.053	1.000

* $P < .01$, ** $P < 0.05$, *** $P < 0.10$; Unmarked coefficients are not significant.

TABLE 3: REGRESSION OF POPULATION GROWTH (PGe) WITH PARAMETERS OF CHANGES IN ECONOMIC AND SOCIODEMOGRAPHIC VARIABLES (Timelag Analysis of Changes)

Explanatory Variables	Regression results of explanatory variables in the equation					
	Corr. coeff. 1971-91	Reg. Beta 1971-91	Reg. Beta 1971-91	S. Reg. Beta 1971-91	Reg. Beta 1971-81	Reg. Beta 1981-91
	(/)	(2)	(3)	W	(5)	
<i>FCp</i>	0.361**	-0.315 (1.04E-04)	—	—	—	—
<i>FPCr</i>	-0.401**	-0.049 (1.33E-05)	—	VR	-0.743*** (2.79E-04)	0.221 (1.97E-04)
<i>PMCr</i>	-0.441*	-0.644** (4.24E-05)	-0.484** (3.17E-05)	VR	-0.904*** (5.59E-05)	-0.584 (6.99E-05)
<i>IMCr</i>	-0.449*	-0.340*** (3.68E-05)	-0.273*** (2.66E-05)	VR	-0.539** (3.86E-05)	-0.651 (5.96E-05)
<i>PLFCr</i>	-0.545*	-0.417*** (1.20E-04)	-0.383 (1.03E-04)	-0.545* (6.75E-05)	-1.831** (2.29E-04)	-0.095 (2.05E-04)
<i>PENAFCr</i>	0.141	0.515** (2.93E-05)	0.431* (2.35E-05)	VR	1.433** (4.40E-05)	0.723 (8.47E-05)
<i>PUCr</i>	-0.282**	-0.047 (6.66E-05)	—	VR	-0.283 (9.65E-05)	0.205 (1.15E-04)
<i>EGOe</i>	-0.117	-0.673** (0.07)	-0.659* (0.05)	VR	-0.036 (0.04)	-0.428 (0.11)
<i>EGPe</i>	0.408**	0.926 (0.04)	0.939* (0.03)	VR (0.03)	—	0.361 (0.05)
<i>EGSe</i>	0.131	0.276 (0.04)	—	— •	—	—
<i>EGTe</i>	-0.135	-0.117 (0.04)	—	—	—	—
R^2	—	0.678	0.647	0.297	0.822	0.750
R^2 (adj.)	—	0.481	0.555	0.272	0.644	0.416
Sig.F	—	0.009	0.000	0.001	0.031	0.170
<i>N</i>	30	30	30	30	15	15

* $P < 0.01$, ** $P < 0.05$, *** $P < 0.10$, Unmarked coefficients are not significant; Standard Errors (SEs) are given in parentheses. Time Lag Adjustment:

Time-Lag Population growth data of 1971 -81 and 1981 -91 with explanatory variables data of 1961 -71 and 1971-81 respectively.

Reg.—Regression; S. Reg.—Stepwise Regression by stepwise procedure; VR - Variables Rejected in the stepwise regression model.

—indicates variables not in the equation.

procedures were tried and it was found that time-lag effects analysis of data provided the much needed lead on the important determinants of population growth as evident from the results in Table 3. The time-lag adjustment (rearrangement) of data in the analysis is as follows: Data of dependent variable population growth for the periods 1971-81 and 1981-91 were correlated with economic and sociodemographic explanatory variables of changes for the periods 1961-71 and 1971-81. Similar rearrangements were made in different sets of time-lag effects analysis of data.

In the time-lag multiple linear regression model (1), with all the variables in the equation, variables economic growth (*EGOe*) and growth in primary sector, infant mortality change, female literacy change, proportion employed in non-agriculture among females and proportion married (females 15-19 age group) change emerged as significant determinants of population growth with an overall R^2 value of 0.481. Five of the above six variables emerged as significant determinants in a selected variables regression model (2). All the sociodemographic variables excepting females employed in non-agriculture sector and economic growth in secondary and tertiary sectors indicate significant correlations with population growth in the time-lag analysis of data. However, a stepwise regression model (3) for the two periods 1971-91, indicates only female literacy change as significant determinant of population growth with an R^2 value of 0.272. This shows that female literacy is the strongest force in population growth transition in India.

Regression analyses of time-lag effects of population growth were also tried separately for the periods 1971-81 and 1981-91. The results with selected variables reveal a striking robustness in the model for the period 1971-81 (model 4) indicting family planning acceptance and proportion married change, infant mortality change, female literacy change and proportion employed in non-agriculture among females change as significant determinants of population growth with R^2 value of 0.644. These five variables are clear set of most important socio-demographic determinants of population growth, which excludes however, the economic growth variables. On the other hand, regression model itself for the period 1981-91 turns out to be insignificant with none of the variables indicated as significant. These results thus confirm the contrasting picture observed in respect of socio-economic change during 1971-81 versus population growth for the period 1981-91 across the states of India. If the results for the period 1981-91 would have emerged like what is being observed for the period 1971-81, the analysis for the combined period 1971-91 would have perhaps indicated more striking results.

The direction of changes indicate that faster growth in the income especially of secondary and tertiary sectors, greater changes in female literacy, infant mortality, proportion married, and family planning acceptance have contributed to lower

population growth. But the direction of changes in respect of two important variables needs to be explained further. The inference that follows here in respect of the positive association between growth in primary sector and population growth is that wherever there has been greater agricultural development, the population growth has been faster. While it is easier to explain this with the view that initial stages of agricultural development have generated higher population growth owing to reduced mortality and increased fecundity, it is very difficult to explain the positive relationship in respect of higher changes in the proportion employed in non-agriculture sector among employed women with higher population growth. However, still it could be argued with a similar view, that at initial stages of transition the increased levels of modernization associated with this phenomenon, could have resulted in a positive effect on population growth.

Factors Affecting Fertility and Family Planning Change

Regression analysis of fertility and family planning acceptance changes were carried out for capturing the principal factors affecting these important dimensions of demographic change. In the multiple linear regression model (Table 4 for the overall data set that includes the three decades period data) without any adjustment for time-lag component with criterion variable relative change in total fertility rate, only female literacy change and economic growth in secondary sector are retained as significant determinants of fertility change with a relatively higher R^2 value of 0.590. In stepwise regression model (2), female literacy change alone is retained as significant determinant of fertility change with an exclusive R^2 value of 0.573. For dependent variable relative change in total fertility rate, the use of log-linear regression model (not shown) did not indicate better explanatory results excepting the predominance of female literacy change as an explanatory variable and therefore log-linear regression model was tried taking the percentage change in total fertility rate as dependent variable, which proved to be more suitable.

Female literacy change continued to be retained as a dominantly significant determinant of fertility change in the log-specified regression model also, which included the full set of data i.e., for the periods 1961-91. Since the data for variable proportion married was not available for 1991, the analysis was delimited to the periods (1961 -71 and 1971-81), and quite surprisingly most of the important factors viz. the economic growth variables excepting tertiary sector, female literacy change, infant mortality change, proportion married among the females in the age group 15-19 and family planning acceptance change are indicated as significant determinants of fertility change with R^2 values exceeding 0.700 (Model 3, 4, and 5). However,

TABLE 4: REGRESSION OF FERTILITY CHANGE (FCp) WITH SOCIODEMOGRAPHIC AND ECONOMIC VARIABLES

Variables	<i>Reg.^(a)</i>	<i>Reg.^(a)</i>	<i>L.Reg</i>	<i>L. Reg.</i>	<i>LSR.</i>
	<i>Beta</i> 1961-91	<i>Beta</i> 1961-91	<i>Beta</i> 1961-81	<i>Beta</i> 1961-81	<i>Beta</i> 1961-81
	(1)	(2)	(3)	(4)	(5)
<i>FPCr</i>	0.136 (0.26)	VR	0.673* (0.03)	0.689* (0.02)	0.620* (0.02)
<i>PMCr</i>	—	—	0.362** (0.00)	0.375* (0.00)	—
<i>IMCr</i>	0.175 (0.13)	VR	-0.222 (0.05)	-0.271*** (0.05)	VR
<i>PLFCr</i>	0.554* (0.32)	0.763* (0.30)	0.278*** (0.02)	0.044 (0.03)	VR
<i>PENAFCr</i>	—	—	—	0.029 (0.04)	VR
<i>PVCr</i>	0.242 (0.37)	VR	0.057 (0.01)	0.045 (0.01)	VR
<i>EGOe</i>	-0.149 (0.32)	VR	0.395*** (0.57)	0.431** (0.54)	VR VR
<i>EGPe</i>	-0.001 (0.21)	VR	-0.498** (0.65)	-0.411*** (0.62)	VR
<i>EGSe</i>	-0.382* (0.18)	VR	0.424** (0.67)	0.351** (0.66)	0.315* (0.37)
<i>EGTe</i>	0.196 (0.20)	VR	-0.119 (0.69)	-0.087 (0.65)	VR
R^2	0.665	0.583	0.785	0.836	0.774
R^2 (adj.)	0.590	0.573	0.703	0.749	0.749
Sig.F	0.0000	0.0000	0.0000	0.0000	0.0000
<i>N</i>	45	45	30	30	30

* $p < 0.01$, *** $P < 0.05$, $P < 0.10$; L. Reg.—Log Linear Regression, LSR.—Log linear Stepwise Regression; @—Regression with dependent variable fertility change—relative (FCr).

because of highly significant intercorrelation between female literacy change and infant mortality change either one of these variable lost its significance as a factor affecting fertility change when different combinations of explanatory variables were tried. Another reason would be that the effect of female literacy probably is more striking during the period 1981-91. The results indicate that income growth, improvements in female literacy and infant mortality which are important background

variables and increase in marital age and family planning acceptance which are important proximate variables, as significant explanatory variables affecting fertility change in India. Variables relative change in urbanisation, and proportion employed in non-agriculture sector among females did not emerge as significant determinants of fertility changes.

The factors affecting the relative changes in family planning acceptance were also examined and the results are presented in Table 5. Regression analysis shows only two

TABLE 5: REGRESSION OF FAMILY PLANNING ACCEPTANCE CHANGE WITH ECONOMIC AND SOCIODEMOGRAPHIC VARIABLES

Explanatory Variables	Regression results of explanatory variables in the equation			
	R. Beta 1961-91	S.R. Beta 1961-91	LLR beta	LLSR beta
	(1)	(2)	(3)	W
IMCr	0.005 (0.08)	VR	-0.097 (0.27)	VR
PENAFCr	-0.184 (0.12)	VR	0.186 (0.34)	VR
PLFCr	0.302* (0.18)	0.301* (0.18)	0.494* (0.14)	0.540* (0.12)
PUCr	-0.188 (0.23)	VR	0.152 (0.11)	0.263*** (0.09)
EGOe	-0.021 (0.20)	VR	-0.368* (2.33)	-0.350* (1.88)
EGPe	-0.260 (0.13)	VR	0.226 (3.30)	VR
EGSe	0.148 (0.11)	VR	0.185 (4.23)	VR
EGTe	0.950* (0.11)	0.741* (0.10)	-0.357*** (5.02)	VR
R ²	0.762	0.737	0.678	0.630
R ² (adj.)	0.717	0.725	0.607	0.603
Sig.F	0.0000	0.0000	0.0000	0.0000
N	45	45	45	45

* $P < 0.05$, ** $P < 0.01$, *** $P < 0.001$, Unmarked Coefficients are not significant.

R - Regression.

SR - Regressing by stepwise procedure.

LLR - Loglinear Regression.

LLSR - Loglinear Regression by Stepwise procedure.

variables i.e., female literacy and economic growth in tertiary sector as significant determinant of family planning acceptance change. However, log-specified regression analysis reveals that (Table 5). overall income growth, faster income growth in tertiary sector, urbanisation change and female literacy change as significant variables causing higher family planning acceptance (couple protection rate). Although more explanatory variables have emerged in the log-linear regression, R^2 value is lower compared to the R^2 value from ordinary regression analysis.

Infant Mortality Change

The results regarding factors affecting infant mortality change are presented in Table 6. In multiple linear regression model (1), variable female literacy change and proportion employed in non-agriculture sector among females change are indicated as significant determinants of infant mortality change with an overall R^2 value of 0.370. In stepwise regression model (2) also, the above two variables are retained as significant determinants of infant mortality change with an R^2 value of 0.396. But log-linear regression model shows a tremendous improvement in the explanatory power of the variables. Apart from the above two variables, economic growth variables such as overall income growth and income growth in primary sector are indicated as significant determinants of infant mortality change with an increased R value of 0.495 (model 3). In stepwise log-linear regression model three of the above four variables excluding overall income growth are retained as significant determinants of infant mortality change with R^2 value of 0.486. Regression analysis of time-lag effects of data did not well explain infant mortality change, which evidently implies that the changes in socio-economic factors cause faster i.e., simultaneous change in infant mortality rate.

Path Analysis

The relationship between the process of socio-economic and demographic changes have been made more explicit in path analysis. Path Analysis has been done as a synthesis of the above analysis of the determinants of infant mortality, marriage, family planning, fertility and population growth. The path analysis is based on series of log-specified regression analysis of significant factors affecting infant mortality, marriage, family planning, fertility and population growth. The direct and indirect effects of the changes in socio-economic and demographic factors on population growth are presented in Table 7. The path diagram (Fig. 1) explains the complex way in which demographic changes have occurred in India. The path specified in the

TABLE 6: REGRESSION OF INFANT MORTALITY CHANGE (*IMCr*) WITH SOCIODEMOGRAPHIC AND ECONOMIC PARAMETERS

Explanatory Variables	Regression results of explanatory variables in the equation			
	Reg. Beta	S. Reg. Beta	LSR beta	LLSR beta
	1961-91	1961-91	1961-91	1961-91
	(1)	(2)	(-3)	(4)
<i>PENAFCr</i>	0.264** (0.13)	0.247** (0.12)	0.375*** (0.19)	0.306* (0.19)
<i>PLFCr</i>	0.560* (0.29)	0.587* (0.28)	-0.473* (0.07)	-0.429* (0.06)
<i>PUCr</i>	0.111 (0.24)	VR	-0.051 (0.06)	VR
<i>EGOe</i>	0.177 (188.54)	VR	-0.230*** (2.79)	VR
<i>EGPe</i>	-0.041 (126,28)	VR	0.301 (1.94)	VR
<i>EGSe</i>	0.273 (165,38)	VR	0.392** (2.44)	0.396* (1.39)
<i>EGTe</i>	-0.283 (192.74)	VR	-0.206 (3.02)	VR
R^2	0.470	0.423	0.576	0.521
R^2 (adj.)	0.370	0.396	0.495	0.486
Sig.F	0.0008	0.0000	0.0000	0.0000
<i>N</i>	45	45	45	45

* $P < 0.01$, ** $P < 0.05$, *** $P < 0.10$, Unmarked coefficients are not significant.

Reg. - Regression.

S. Reg. - Regression by stepwise procedure

LLR - Loglinear Regression

LLSR - Loglinear Regression by stepwise procedure

diagram are those which showed significant beta coefficients. All the socio-economic variables show their impact on the demographic processes of marriage, family planning use, infant mortality, fertility and population growth. Economic growth variables show clear effects on family planning and fertility, while female work status show significant effects on proportion married and infant mortality. But, path analysis again reiterates the strong effect of female education on the infant mortality change, changes in marital composition of women and family planning use. This is seen more clearly through the paths and their coefficients. The causal relationships underscore

TABLE 7: DECOMPOSITION OF EFFECTS ON INFANT MORTALITY, MARRIAGE, sFAMILY PLANNING, FERTILITY AND POPULATION GROWTH

<i>Variables</i>	<i>Direct effect</i>	<i>Indirect effect</i>	<i>Total effect</i>
I. On Infant Mortality			
1. <i>PENAFCr</i>	0.375*	—	0.375*
2. <i>PLFCr</i>	-0.528*	—	-0.528*
3. <i>PUCr</i>	-0.051	-0.210	-0.261
4. <i>EGPe</i>	0.301**	0.025	0.326**
5. <i>EGSe</i>	0.392*	0.095	0.487*
6. <i>EGTe</i>	-0.206	0.637	0.431*
7. <i>EGOe</i>	-0.230	0.226	-0.004
II. On Marriage			
1. <i>PENAFCr</i>	-0.292	—	-0.292
2. <i>PLFCr</i>	0.723*	—	0.723*
3. <i>PUCr</i>	0.048	0.200	0.248
4. <i>EGPe</i>	-0.389	0.450	0.061
5. <i>EGSe</i>	0.078	-0.031	0.047
6. <i>EGTe</i>	-0.057	-0.010	-0.067
7. <i>EGOe</i>	0.131	-0.364	-0.233
III On Family Planning			
1. <i>IMR</i>	-0.317**	—	-0.317**
2. <i>PENAFCr</i>	0.186	-0.078	0.108
3. <i>PLFCr</i>	0.694*	—	0.694*
4. <i>PUCr</i>	0.263	0.232	0.495*
5. <i>EGPe</i>	0.226	-0.319	-0.093
6. <i>EGSe</i>	0.185	-0.434	-0.229
7. <i>EGTe</i>	-0.357	-0.036	-0.393*
8. <i>EGOe</i>	-0.368*	0.005	-0.363*
IV. On Fertility			
1. <i>PUCr</i>	0.385*	—	0.385*
2. <i>FPCr</i>	0.434*	—	0.434*
3. <i>IMCr</i>	-0.401*	—	-0.401*
4. <i>PENAFCr</i>	0.029	0.141	0.170
5. <i>PLFCr</i>	0.044	0.532	0.576
6. <i>PUCr</i>	0.045	0.322	0.367*
7. <i>EGPe</i>	-0.411*	0.456	0.045
8. <i>EGSe</i>	0.351**	-0.325	0.026
9. <i>EGTe</i>	-0.087	-0.020	-0.107
10. <i>EGOe</i>	0.431*	-0.352	0.079

V. On Population Growth

1. <i>FCp</i>	-0.211***	—	-0.211***
2. <i>FPCr</i>	—	0.332	-0.332**
3. <i>PMCr</i>	—	-0.231	-0.231***
4. <i>IMCr</i>	0.325**	0.155	0.480*
5. <i>PENAFCr</i>	-0.031	0.117	0.086
6. <i>PLFCr</i>	-0.274**	-0.165	-0.439*
7. <i>PUCr</i>	0.126	-0.279	-0.153
8. <i>EGPe</i>	0.161	0,014	0.175
9. <i>EGSe</i>	-0.050	0.301	0.251**
10 <i>EGTe</i>	-0.023	0.277	0.254**
11 <i>EGOe</i>	-0.219	0.198	-0.021

Note: * $P < 0.01$, ** $P < 0.05$

*** $P < 0.10$

that changes occur beginning from socio-economic developmental change, percolating to proximate variables, fertility and ultimately population growth. The relationship follow more of log-linear form than a simple linear relationship. And this chain of changes have occurred over a considerable period of time as revealed in the time-lag analysis.

Conclusion

This analysis is an attempt to examine the complex pattern of the association between the processes of socio-economic and demographic changes using more suitable procedures. The different procedures and models used in the analysis clarify a number of issues. It is found that time-lag analysis of data with the use of conventional multiple linear regression model is more appropriate for examining the factors affecting population growth, whereas log-linear models are more suitable for examining the factors affecting fertility, family planning and infant mortality changes. The socio-economic factors are seen to have more quicker effects on infant mortality, fertility, and family planning acceptance, while population growth rates have been impinged after certain amount of time-lag period. This is the reason why changes in socio-economic variables did not emerge as significant determinants of population growth in simple regression, where as all of them emerge as strong variables affecting population growth in a time-lag analysis. Path analysis also confirms this and also explains how socio-economic and demographic factors affect population growth variously as a complex chain of events. The new transformation of variables and fitting of more appropriate models including path analysis have captured in the best positive way the principal determinants of demographic changes taking place in India.

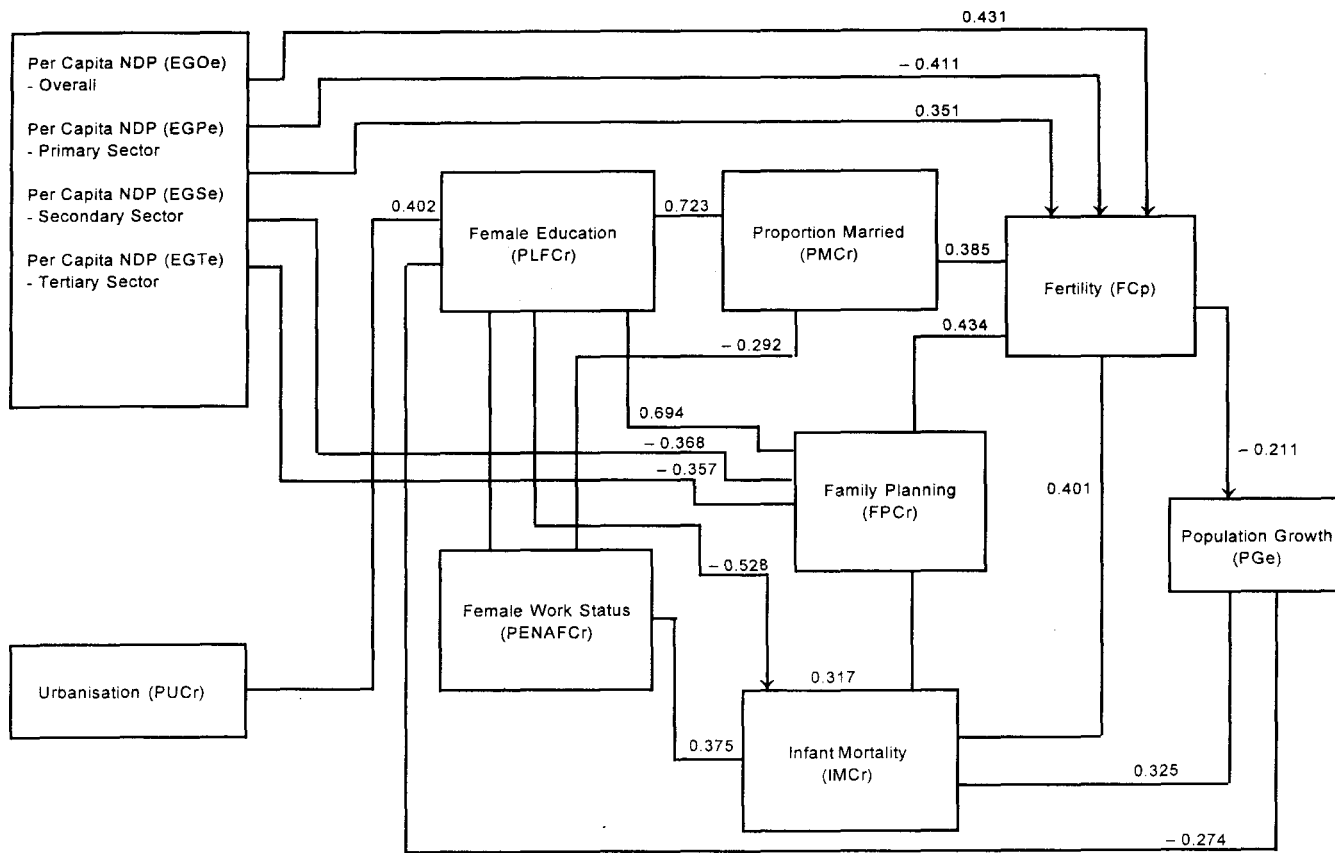

Fig. 1. Path Model: Truncated model with only significant paths shown of the factors variously affecting the demographic changes in India using results from log-specified regression analyses (as shown in Table 7).

Although socio-economic factors have more quicker effects on proximate determinants and fertility, the relationship follow log-linear form in variables and that is why ordinary regression does not indicate many of the variables as significant determinants.

Faster income growth especially in the manufacturing and tertiary sector, increasing trend in female literacy and family planning acceptance and the declining trends in infant mortality and the proportion married among females in the age group 15-19, have contributed towards lower population growth according to the trends recorded across the major states and in India over the three decades from 1961 to 1991. However, growth in agriculture sector and higher share of employment in non-agricultural sector among employed women have not contributed to lower population growth. More clear results would have emerged but for the lack of relationships shown for the period 1981-91.

Faster income growth, improvements in female literacy and infant mortality declines are found to be important background variables, and increase in female marital age and family planning acceptance are important proximate variables which have caused fertility decline in India. Faster income growth in tertiary sector and increase in female literacy are highly significant factors causing higher acceptance of family planning. And income growth in primary sector, improvements in female literacy and proportion employed in non-agriculture among females are significant determinants of infant mortality decline.

Female literacy is the most predominant determinant of demographic changes occurring in India. Rate of economic growth is also one of the significant determinant of fertility, family planning acceptance-and infant mortality changes and population growth. The role of economic growth by different sectors as factors affecting faster demographic changes and slower population growth, is considerably well established in this analysis through the use of improvised transformation of variables and explanatory models.

References

- Blanchet, Didier, 1991, On interpreting observed relationships between population growth and economic growth: A graphical exposition. *Population and Development Review*, 17(1). Box, G. E. P. and Tidwell, P. W., 1962, Transformation of independent variables. *Technometrics*, 4. Box, G. E. P. and Cox, D. R., 1964, An analysis of transformation. *Journal of the Royal Statistical Society Series-B*, 26: 211-243.
- Census of India, *Primary Census Abstract, 1961 to 1991*. New Delhi, Government of India. Centre for monitoring Indian Economy, 1991, *Basic Statistics Relating to Indian Economy*, Vol. 1. All India.

- Centre for Monitoring Indian Economy, 1991, *Basic Statistics Relating to Indian Economy*, Vol. II.
- sStates. Chandhok, H. L. and the Policy Group, 1990, *Indian Data Base: The Economy*, Vol. I and 11.
- New
Delhi, LM Books. Mason, Andrew, Suits, Daniel B., Koo, Sung Yeal, Ogawa, Naohiro, Dhananiramai, Mathana and
Sigit, Hananto, 1986, *Population Growth and Economic Development: Lessons from Selected Asian Countries*. New York, United Nations Fund for Population Activities. Rele, J. R., 1987, Fertility levels and trends in India 1951-81. *Population and Development Review*,
13 (3). Wheeler, David, 1980, *Human Resource Development and Economic Growth in Developing Countries: A Simultaneous Model*. World Bank Staff Working Paper No. 467, Washington, D. C., The World Bank.